

Outdoor Emergency Lighting Application Guide



Outdoor Emergency Lighting Application Guide

Table of Contents:

Subject	Page
Introduction.....	1
Power Sources	2
Normally On Outdoor Emergency Lighting Options	
• Integral Battery Pack – ELDW/ELDWC.....	3
• Remote Battery Pack – ELDWR	3
• Emergency Circuit 12-Volt – DC12	4
• Aeris™ Luminaires, Architectural Sconce and TWAC – DC12	5
• Emergency Circuit – EC.....	6
• Overview by Product.....	7
Normally Off Outdoor Emergency Lighting Options	
• Remote Fixtures and Overview by Product	8
• Stand-Alone Units and Overview by Product.....	9
Codes	10
Appendix A	10
Appendix B	11

Outdoor Emergency Lighting Application Guide

Introduction

Traditional emergency lighting and exit signs have been primarily focused on guiding the interior occupants of a building to the nearest exit in the event of an emergency. Today, an additional emphasis is being placed on not only getting occupants to the exit of the building, but also getting them to and along a path of safety once they are out of the building.

The NFPA Life Safety Code requires emergency illumination of the path of egress away from the building (exit discharge) and leading “to a public way.” The safe public area or “public way” is described in the code as “a street or alley or other similar parcel of land essentially open to the outside air deeded dedicated or otherwise permanently appropriated to the public for public use and having a clear width and height...”

Outdoor emergency applications fall into two categories: damp location or wet location. According to Chapter 1, Article 100 of the 2002 National Electric Code, damp locations include “...*partially protected locations under canopies, marquees, roofed open porches, and like locations...*” whereas wet location is partially defined as “...*locations subject to saturation with water or other liquids, such as vehicle washing areas; and in unprotected locations exposed to weather.*”

Lithonia Lighting is pleased to provide this Outdoor Emergency Lighting Application Guide as a resource to identify our complete list of solutions for outdoor emergency applications, including both *normally on* outdoor fixtures that switch to emergency mode when needed, and *normally off* emergency fixtures that are approved for outdoor use.

Power Sources

Traditional building-mounted fixtures on generators or AC power systems can be used for both normal and emergency egress lighting. An emergency generator provides continuous AC power to the fixtures on the emergency circuit(s) during loss of normal power. An AC power system utilizes batteries and converts DC to AC power for the fixtures on the emergency circuit(s) during loss of normal power.

When using incandescent or fluorescent lamps for emergency egress lighting, an emergency generator or interruptible AC power system can be used. If using HID lamps, a fast-transfer AC power system or uninterruptible power supply is required to switch the power quickly enough so that the HID lamp does not lose its arc and extinguish.

Power Source System Type	Lamp Type	Lamp Watt	Start Temp (F)*	Lamp Life (in hours)*	Lamp Lumens (initial)*
Generator/Interruptible AC Power System	Incandescent	75A19	n/a	750	1,210
		100A19	n/a	750	1,750
	Compact Fluor.	26DTT	-5 ⁰	10,000	1,800
		28TT	-20 ⁰	10,000	1,600
		26TRT	-5 ⁰	12,000	1,800
		32TRT	-5 ⁰	12,000	2,400
		42TRT	-5 ⁰	12,000	3,200
Fast Transfer AC Power System	HPS	35S	-40 ⁰	16,000	2,250
		50S	-40 ⁰	24,000	4,000
		70S	-40 ⁰	24,000	6,300
		100S	-40 ⁰	24,000	9,500
		150S	-40 ⁰	24,000	15,800
		200S	-40 ⁰	24,000	22,000
		250S	-40 ⁰	24,000	29,000
	Metal Halide	50M	-20 ⁰	7,500	3,450
		70M	-20 ⁰	10,000	5,200
		100M	-20 ⁰	10,000	8,500
		150M	-20 ⁰	10,000	13,300
		175M	-20 ⁰	10,000	12,800
		250M	-20 ⁰	10,000	20,000
		*Information taken from various lamp manufacturers' literature.			

Normally On Outdoor Emergency Lighting

Integral Emergency Battery Pack – ELDW/ELDWC

The ELDW (ELDWC for cold weather applications) option is an integral emergency battery pack that operates compact fluorescent lamps at a reduced lumen output for a minimum of 90 minutes. When AC power is restored, the ELDW returns to charging mode and will be completely re-charged in 24 hours.

With the ELDW option, an indicator light and test switch are provided with the fixture. When AC power is applied, the indicator light is illuminated. The test switch provides a means for checking the emergency battery pack to make sure that it is functioning properly. Although no routine maintenance is required to keep the emergency battery pack functional, it is required that the emergency operation be tested at 30-day intervals for a minimum of 30 seconds and that a 90-minute discharge test be completed once a year. ELDWR, a remote version of this battery pack, is also available with the Architectural Sconce Series.

The ELDW and ELDWR options are UL Listed for wet locations and are rated to operate in ambient temperatures as low as 32°F (0°C). These battery packs have a life expectancy of seven to 10 years. The ELDWC option operates in ambient temperatures as low as -4°F (-20°C).

Battery Pack	ELDW ¹				ELDWC ²			ELDWR ³			ELDWRPS ⁴		
	Gateway [®] VGR1C, VGR2C	Architectural Sconce WSR, WST, WSQ, MRW	Aeris™ ASW	Emergency Light Output	Architectural Sconce WSR, WST	General Purpose TWP	Emergency Light Output	Architectural Sconce WSR, WST, WSQ, MRW	Architectural Sconce WSTM	Aeris™ ASW	Architectural Sconce WSR, WST, WSQ, MRW	Architectural Sconce WSTM	Aeris™ ASW
13DTT (one lamp)	X			350									
2/13DTT	X			425									
18DTT (one lamp)	X			300									
2/18DTT	X			525									
26DTT (one lamp)	X	X	X	450	X	X	700	X	X	X	X	X	X
2/26DTT		X	X	725		X	700	X	X	X	X	X	X
26TRT (one lamp)	X	X	X	450	X	X	700	X	X	X	X	X	X
2/26TRT		X	X	725		X	700	X	X	X	X	X	X
32TRT (one lamp)	X	X	X	575	X	X	1250	X	X	X	X	X	X
2/32TRT						X	1250	X	X	X	X	X	X
42TRT (one lamp)	X	X	X	750	X	X	1250	X	X	X	X	X	X
2/42TRT						X	1250	X	X	X	X	X	X

¹ Integral battery pack with 32°F min. operating temp. ² Integral battery pack with -4°F min. operating temp.
³ Remote ready fixture option for Bodine B30 battery pack, 32°F min. operating temp. ⁴ Remote ready fixture option for Power Sentry PS1400 or PSDL3 battery packs, 32°F min. operating temp.
^{*}For ELDWC used with 2-lamp configurations, only one lamp operates in emergency mode.

The ELDW option is currently available in the Aeris™ ASW luminaire, Architectural Sconce products and Gateway® VGR-C products. The ELDWC option is available in our Architectural Sconce WSR and WST products as well as our general-purpose TWP wall pack fixtures. The chart above summarizes the lamp wattage capability for products with the ELDW/ELDWC/ELDWR options. See Appendix A for a matrix of available ELDWR fluorescent battery packs. Light output registers at 25°C ambient.

The amount of emergency illumination provided is dependent upon the number, wattage and type of lamps selected, and the lamp manufacturer. Initial emergency illumination provided is typically 350 to 1250 lumens (refer to chart above for specific lamp types). With an ELDW or ELDWR battery pack, if (2) 26-watt lamps are selected, light output is evenly divided between the lamps for 725 total lumens. When the ELDWC battery pack is selected, only one lamp will be illuminated in emergency back-up mode.

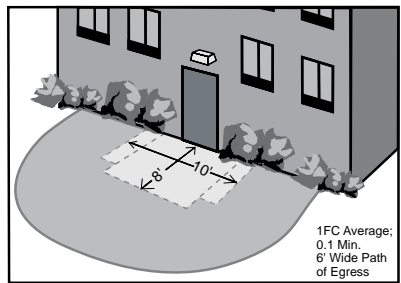

WSR with ELDW (2/26 DTT)

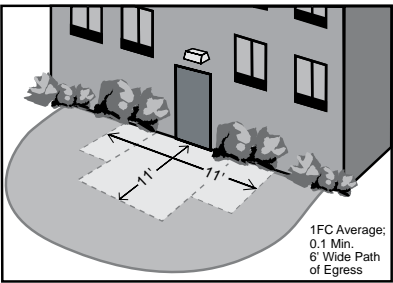

WST with ELDW (42TRT)

Normally On Outdoor Emergency Lighting Options

Emergency Circuit 12-Volt – DC12

To address the growing need of emergency egress lighting and the requirements of the Life Safety Code, Lithonia Lighting now provides the DC12 emergency circuit option. This feature equips the fixture with one or two 12-volt DC bayonet base 20-watt or 35-watt MR11 lamps. Low-voltage lamps, powered by an external battery source, are provided in addition to the HID lamps and will supply illumination along the path of egress when there is a power interruption to the primary HID source.

In a typical application, the emergency 12-volt power would be supplied from a battery source external to the fixture, usually located within the building by an emergency lighting unit such as Lithonia's Indura® or Titan® Series (*refer to diagram A above right*). Labeled leads that connect to the battery source are provided.

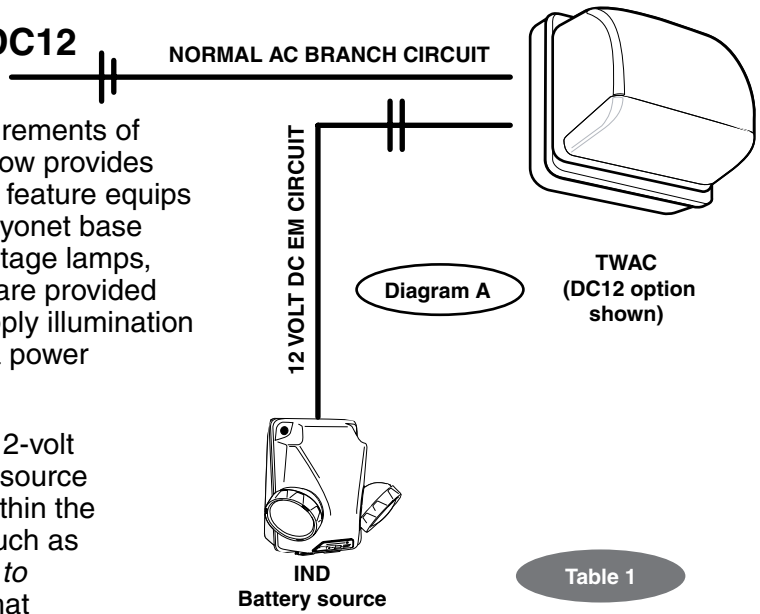

Table 1

DC Options	Initial Lumens (per lamp)	LAMP TYPE	
		10° Spot	29° Flood
DC2012 (1) 20W lamp	350		X
2DC2012 (2) 20W lamps	350	X	X
DC12 (1) 35W lamp	660		X
2DC12 (2) 35W lamps	660	X	X

12-VOLT DC VOLTAGE DROP TABLE
Distance between battery pack and luminaire
(5% maximum voltage drop)

Table 2

Wire Size	DC2012 (1) 20W lamp	2DC2012 (2) 20W lamps	DC12 (1) 35W lamp	2DC12 (2) 35W lamps
16 AWG	35'	15'	20'	10'
14 AWG	50'	25'	30'	15'
12 AWG	85'	40'	50'	25'
10 AWG	140'	70'	80'	40'

Table 2 to the left illustrates the distance, by wire size, allowed between the battery source and emergency luminaire at 5% maximum voltage drop per National Electric Code.

Table 3

Lithonia Emergency Products

Series	Nomenclature	Lamp Heads Watts/lamp	Output Volts	Remote Wattage Available
Indura Units	IND12150 XTRA	9	12	132
Titan Units	ELT125 TD	12	12	101

Other emergency products available; please refer to the PSG or www.lithonia.com.

If using an HID source as your primary lamp, it is recommended that a time delay (TD) option be used in the emergency lighting unit so that the DC12 lamp stays on until the HID lamps come up to full brightness. The chart above outlines a few of the battery sources available from Lithonia Emergency Systems that will work in conjunction with the DC12 option in Lithonia HID products.

Normally On Outdoor Emergency Lighting

Aeris™ Luminaires, Architectural Sconces and TWAC – DC12

Aeris ASW luminaires and Architectural Sconces (WSR, WST and WSQ) are available with either one- or two-lamp configurations of 20-watt or 35-watt MR11 lamps that fit into the same area on the reflector tray as the test switch and indicator light for the integral battery pack. The application information to the right demonstrates the area of coverage with the architectural sconce mounted at 12', while the DC12 option is in operation.

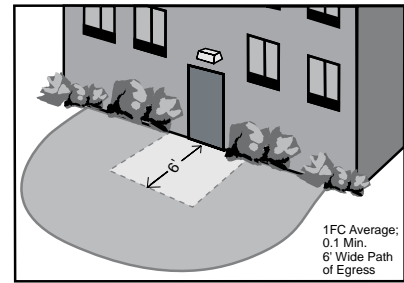

WSR with DC12

The DC12 option is also available in the TWAC Series with either 20- or 35-watt lamps in one- or two-lamp configurations. The DC12 lamps mount to a special fixed bracket attached to the component cover on either side of the main reflector. Table 1 on page 4 details the ordering information for each option and the lamp data specific to that option. Providing two lamps will prevent leaving an area in total darkness if one of the lamps should fail.

The application information below demonstrates the area of coverage for each option.

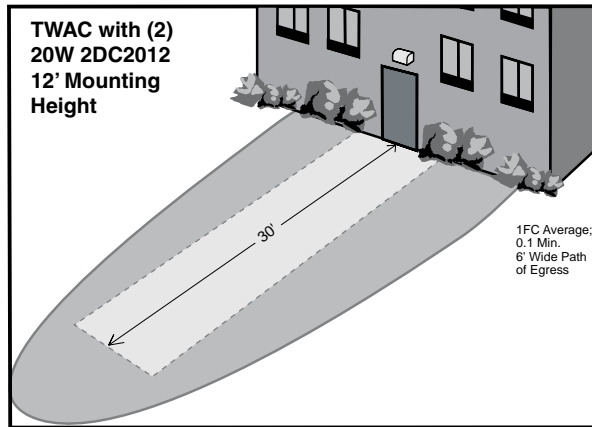

TWAC with 2DC2012

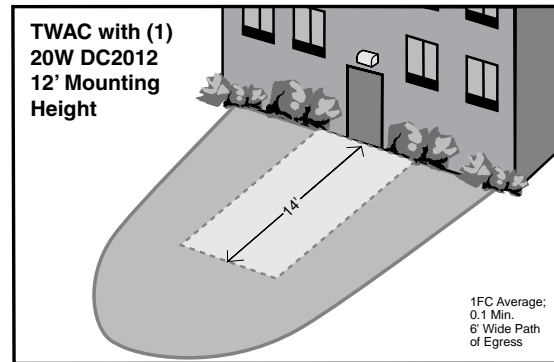

TWAC with DC2012

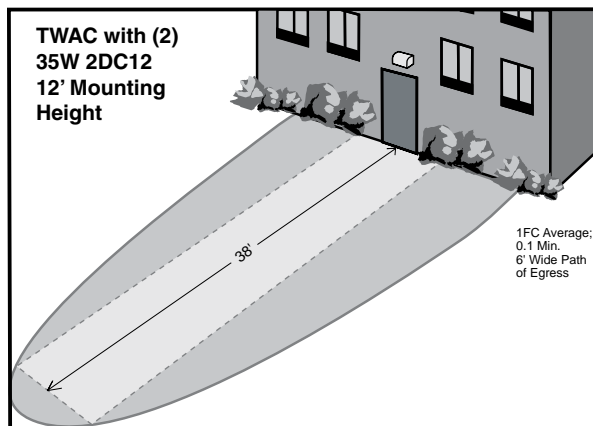

TWAC with 2DC12

12-Volt Emergency Circuit	ASW	WSR	WST	WSQ	TWAC	Min. Size Quantum® Emergency Unit	...with time-delay option**
DC12 (35-watt MR11 lamp)	X	X	X	X	X	ELM1254	ELM1254 N TD
2DC12 (2 - 35-watt MR11 lamps)	X	X	X	X	X	ELM1272 RO	ELM1272 RO TD
DC2012 (20-watt MR11 lamp)	X	X	X	X	X	ELM1254	ELM1254 N TD
2DC2012 (2 - 20-watt MR11 lamps)	X	X	X	X	X	ELM1254 RO	ELM1254 RO N TD

**Time-delay option enables fixture to continue emergency mode operation after AC power has been restored while HID lamps return to full illumination.

Normally On Outdoor Emergency Lighting Options

Emergency Circuit – EC

























The EC option provides a separate, normally off 120-volt quartz or incandescent double-contact bayonet socket that can be connected to the generator or AC power system. The light output of the emergency lamp in the EC option is usually less than the light output of the normal lamp in the fixture. The EC option is available in many of our outdoor products, including area, building-mounted, rough service and floodlighting. However, because there is a range of lamp wattages capable of operating the EC circuit, the lamp provided (*or supplied by others*) with the option does vary among these different product types. The rough service VR1, VR2 and VR3 products are offered with a DC option which provides only the DC bayonet socket for emergency egress lighting (can use up to 25W 6W/6V or 12W/12V). Following is the information regarding the maximum emergency lamp wattage capability and availability with each product type:

<i>Emergency Circuit (EC)</i>		<i>Maximum Wattage Capability</i>	<i>Lamp Included</i>	<i>Socket Type</i>
Area Lighting	AS / AST	100W (AS1), 250W (AS2)	No	DC Bayonet
	MR / MRT	100W (MR1), 250W (MR2)	No	DC Bayonet
	KSE	250W	No	DC Bayonet
	KSF	250W	No	DC Bayonet
	KAD / KADT	250W	No	DC Bayonet
	KAR	250W	No	DC Bayonet
	KVF	250W	No	DC Bayonet
	KVS	250W	No	DC Bayonet
	KVE	250W	No	DC Bayonet
	KVR	250W	No	DC Bayonet
	KKS	250W	No	DC Bayonet
	KKR	250W	No	DC Bayonet
	KQS	250W	No	DC Bayonet
Wall-Mounted Lighting	ASW	250W	No	DC Bayonet
	MRW	100W	No	DC Bayonet
	WSR, WST, WSTM, WSO	25W	Yes	DC Bayonet
	WFL3	100W	No	DC Bayonet
	TWA, TWAC	100W	No	DC Bayonet
	TWH	150W	No	DC Bayonet
	TWP	250W	No	DC Bayonet
Floodlighting	ASF2	250W	No	DC Bayonet
	KFL3	100W	No	DC Bayonet
	TFA	250W	No	DC Bayonet
	TFR	250W	No	DC Bayonet
	TFL	250W	No	DC Bayonet
Rough Service Lighting	VGR1C, VGR2C	25W	Yes	DC Bayonet
	VG01C, VG02C	25W	Yes	DC Bayonet
	VG03C	25W	Yes	DC Bayonet

Refer to the Outdoor Emergency Application Guide at <http://ablweb> for further details.

Normally On Outdoor Emergency Lighting

Overview by Product

	Fixture	Description	EC	ELDW* (Integral emergency battery pack)	DC12
Area Lighting	Aeris™ Area AS	 Architectural die-cast size 1 and 2	X		
	Omero™ Area MR	 Architectural die-cast size 1 and 2	X		
	KSE	 Square size 1 and 2	X		
	KSF	 Rectangular size 1, 2 and 3	X		
	Contour® KAD	 Soft-corner square flat lens	X		
	KAR	 Round size 1, 2 and 3	X		
	KVF	 Square	X		
Wall-Mounted Lighting	Aeris™ Wall ASW	 Architectural	X	X	X
	Omero™ Wall MRW	 Architectural	X	X	X
	WSR, WST WSTM, WSQ	 Decorative	X	X	X
	WFL (size 3 only)	 Architectural	X		
	Contour® TWAC	 Cutoff mini	X		X
	Contour® TWA	 Mini	X		
	TWH	 Glass refractor	X		
	TWP	 Polycarbonate refractor	X		
Floodlighting	Aeris™ Flood ASF (size 2 only)	 Architectural	X		
	KFL (size 3 only)	 Architectural	X		
	Contour® TFA	 Large	X		
	Contour® TFR	 Medium	X		
	Contour® TFL	 Medium	X		
Rough Service Lighting	Gateway® VGR1C/VGR2C	 Round eyelid	X	X	
	Gateway® VGO1C	 Oval open face	X		
	Gateway® VGO2C	 Oval horizontal eyelid	X		
	Gateway® VGO3C	 Oval vertical eyelid	X		

*For an up-to-date list of available fixtures, refer to lithonia.com or the Product Selection Guide.











Normally Off Outdoor Emergency Lighting Options

Remote Fixtures

In general, remote fixtures offer advantages such as lower initial costs and better aesthetics compared to typical emergency battery units. These advantages are more prevalent in environments that require special ratings such as wet location and NEMA 4X, or in areas where ambient temperatures can diminish capacity or life. Both occurrences are common with the exit discharge.

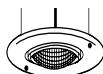
In many instances, the battery unit can be installed in a normal or conditioned environment with the remote heads located in the areas that require special ratings.

The chart on this page details normally off remote fixtures that may be used in damp or wet locations as well as popular sealed-beam recessed remote heads. Lamp type, voltage and wattage can be found in the Product Selection Guide and on the specific product specification sheets. The stand-alone units listed on the following page can be used to run the remote fixtures.



Fixture	Description	Wet	Damp	Cold Weather
ELA AFN DB 	Architectural die-cast	X	X	X (-40°C to 60°C)
ELA OSL 	Recessed outdoor step light, die-cast aluminum 12V	X	X	
ELA Core Light 	Recessed round outdoor core light, die-cast aluminum 6V, 12V	X	X	
ELA OMC* 	Surface-mount outdoor mini cylinder, die-cast aluminum 6V, 12V	X	X	
ELA WP 	Surface-mount weatherproof aluminum 12V	X	X	
ELA NX* 	Surface-mount wet location sealed glass 6V, 12V	X	X	
ELA Z 	Surface-mount Class 1, Div. 2, haz. location, sealed glass 6V, 12V	X	X	
ELA RG 	Recessed Gimbal PAR36 SB lamp up to 25W			
6" ELA OC 3" ELA LV3 OC 	PAR36 SB lamp up to 25W MR16 SB lamp up to 20W			
6" ELA SB 3" ELA LV3 SB 	PAR36 SB lamp up to 25W MR16 SB lamp up to 20W			
6" ELA EB 3" ELA LV3 EB 	PAR36 SB lamp up to 25W MR16 SB lamp up to 20W			

*These remote fixtures are offered in single- and double-head versions.

Normally Off Outdoor Emergency Lighting Options

Stand-Alone Units

Not only can your unit equipment be used as a power source, but it can be used as stand-alone equipment. The chart below is an overview of stand-alone emergency units that are suitable for outdoor use; for other fixtures refer to www.lithonia.com or the Product Selection Guide.

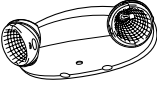
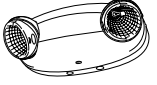
Fixture	Description	Wet	Damp	Cold Weather	NEMA 4X/IP66
AFN DB EXT 	Architectural die-cast emergency unit	X	X	X (-18°C to 50°C)	
IND618-6100 IND1236-12450 IND24100-2450 	Industrial emergency unit		X	X (ULT package) (-40°C to 55°C)	
INDX618-6100 INDX1236-12125 INDX24100 	Industrial NEMA 4X emergency unit	X	X	X (ULT package) (-40°C to 55°C)	X
ELM ELM2 	Thermoplastic emergency unit				X
ELM618-654 ELM1254-1272 	High-capacity thermoplastic emergency unit				X

PERFORMANCE

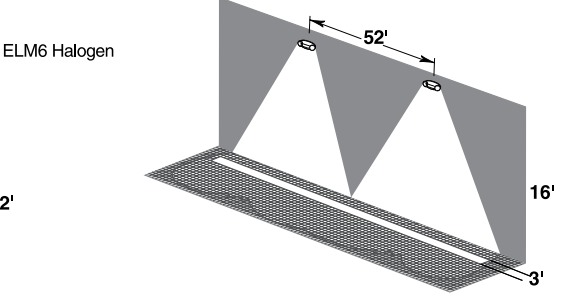
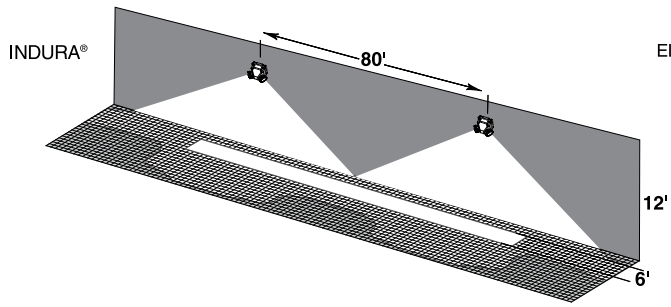
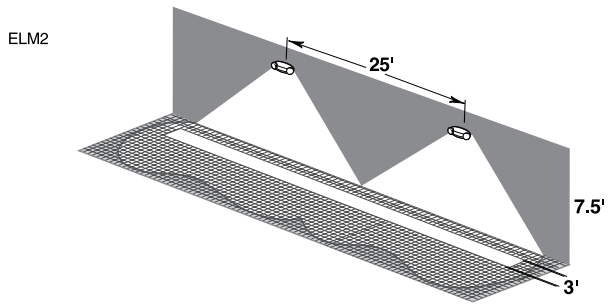
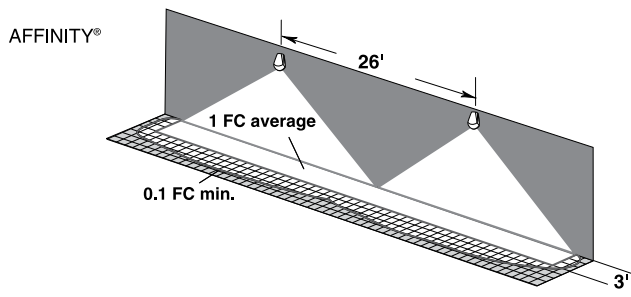

Codes

Life Safety Code® (NFPA 101®)

Section 3.3.151 Means of Egress:

A continuous and unobstructed way of travel from any point in a building or structure to a public way consisting of three separate and distinct parts: (1) the exit access, (2) the exit, and (3) the exit discharge.

Section 3.3.193 Public Way:

A street, alley, or other similar parcel of land essentially open to the outside air deeded, dedicated, or otherwise permanently appropriated to the public for public use and having a clear width and height of not less than 10 ft (3050 mm).

Section 7.9 Emergency Lighting:

7.9.1.2 ... exit discharge shall include only designated stairs, ramps, aisles, walkways, and escalators leading to a public way.

Section 7.9.2 Performance of System:

7.9.2.1 Emergency illumination shall be provided for not less than 1-1/2 hours in the event of failure of normal lighting. Emergency lighting facilities shall be arranged to provide initial illumination that is not less than an average of 1 ft-candle (10.8 lux) and, at any point, not less than 0.1 ft-candle (1.1 lux), measured along the path of egress at floor level. Illumination levels shall be permitted to decline to not less than an average of 0.6 ft-candle (6.5 lux) and, at any point, not less than 0.06 ft-candle (0.65 lux) at the end of the 11D 2 hours. A maximum-to-minimum illumination uniformity ratio of 40 to 1 shall not be exceeded.

Since exit discharge is one of the three components defined as the “means of egress” per 3.3.151 of the Life Safety Code and since 7.9.1.2 also includes exit discharge, many authorities having jurisdiction have concluded that the lighting levels of 7.9.2 apply in full. *Note: Variations may exist depending upon the interpretation of codes in your area.*

Reprinted with permission from NFPA 101® Life Safety Code®, 2006 Edition. National Fire Protection Association, Quincy, Massachusetts 02269. This reprinted material is not the complete and official position of the NFPA on the referenced subject, which is represented only by the standard in its entirety.

Appendix A

Fluorescent Battery Packs (for use with ELDWR outdoor fixture option)

Designate the following remote-ready fixture options:

ELDWR – Remote-ready fixture option for Bodine® B30 battery pack, 32° minimum operation temperature.

ELDWRPS – Remote-ready fixture option for Power Sentry® PSDL3 battery pack, 32° minimum operating temperature.

Lamp Compatibility

Lamp Type	Wattage	PS1400	PSDL3	Bodine® B30
Lumens		1100-1400	580-1070	1450-3500
PL Twin-Tube (2-Pin)	9-13			1,2
PL Quad-Tube (2-Pin)	13-26			1,2
PL Twin-Tube (4-Pin)	9-13	1	1	1,2
PL Quad-Tube (4-Pin)	13-26	1,2	1,2	1,2
Triple-Tube (4-Pin)	18-32	1,2	1,2	1,2
Triple-Tube (4-Pin)	42	1	1	1,2

NOTES: *Based on the lumen output of the lamp; provides full light output.

1 One-lamp emergency operation for 1, 2, 3 or 4-lamp ballasts.

2 Two-lamp emergency operation for 2, 3, or 4-lamp ballasts.

Accessories

PSSD	Field-installable self-diagnostic module.
ELA TSPLP	Remote or replacement test switch/pilot light. Mounts up to 25' away from fixture.
ELA TSPLPSD	Remote or replacement test switch/pilot light for self-diagnostics. Mounts up to 25' away from fixture.
ELA PSRME	Remote mounting enclosure.
ELA PSMKSD	External mounting kit for self-diagnostics module.
ELA PSMK	External mounting kit; two required.

Appendix B

OUTDOOR Emergency Option Reference Guide

12-Volt Emergency Circuit	ASW	WSR	WST	WSQ	TWAC	Min. Size Quantum® Emergency Unit	...with time-delay option**
DC12 (35-watt MR11 lamp)	X	X	X	X	X	ELM1254	ELM1254 N TD
2DC12 (2 - 35-watt MR11 lamps)	X	X	X	X	X	ELM1272 RO	ELM1272 RO TD
DC2012 (20-watt MR11 lamp)	X	X	X	X	X	ELM1254	ELM1254 N TD
2DC2012 (2 - 20-watt MR11 lamps)	X	X	X	X	X	ELM1254 RO	ELM1254 RO N TD

**Time-delay option enables fixture to continue emergency mode operation after AC power has been restored while HID lamps return to full illumination.

Battery Pack	ELDW ¹				ELDWC ²			ELDWR ³			ELDWRPS ⁴		
	Gateway® VGR1C, VGR2C	Architectural Sconce WSR, WST, WSQ, MRW	Aeris™ ASW	Emergency Light Output	Architectural Sconce WSR, WST	General Purpose TWP	Emergency Light Output	Architectural Sconce WSR, WST, WSQ, MRW	Architectural Sconce WSTM	Aeris™ ASW	Architectural Sconce WSR, WST, WSQ, MRW	Architectural Sconce WSTM	Aeris™ ASW
Lamp Options (# of lamps/wattage)													
13DTT (one lamp)	X			350									
2/13DTT	X			425									
18DTT (one lamp)	X			300									
2/18DTT	X			525									
26DTT (one lamp)	X	X	X	450	X	X	700	X	X	X	X	X	X
2/26DTT		X	X	725		X	700	X	X	X	X	X	X
26TRT (one lamp)	X	X	X	450	X	X	700	X	X	X	X	X	X
2/26TRT		X	X	725		X	700	X	X	X	X	X	X
32TRT (one lamp)	X	X	X	575	X	X	1250	X	X	X	X	X	X
2/32TRT						X	1250	X	X	X	X	X	X
42TRT (one lamp)	X	X	X	750	X	X	1250	X	X	X	X	X	X
2/42TRT						X	1250	X	X	X	X	X	X

¹ Integral battery pack with 32°F min. operating temp. ² Integral battery pack with -4°F min. operating temp.

³ Remote ready fixture option for Bodine B30 battery pack, 32°F min. operating temp. ⁴ Remote ready fixture option for Power Sentry PS1400 or PSDL3 battery packs, 32°F min. operating temp.

*For ELDWC used with 2-lamp configurations, only one lamp operates in emergency mode.



Emergency Circuit (EC)	Maximum Wattage Capability	Lamp Included	Socket Type	
Area Lighting	AS / AST	100W (AS1), 250W (AS2)	No	DC Bayonet
	MR / MRT	100W (MR1), 250W (MR2)	No	DC Bayonet
	KSE	250W	No	DC Bayonet
	KSF	250W	No	DC Bayonet
	KAD / KADT	250W	No	DC Bayonet
	KAR	250W	No	DC Bayonet
	KVF	250W	No	DC Bayonet
	KVS	250W	No	DC Bayonet
	KVE	250W	No	DC Bayonet
	KVR	250W	No	DC Bayonet
Wall-Mounted Lighting	ASW	250W	No	DC Bayonet
	MRW	100W	No	DC Bayonet
	WSR, WST, WSTM, WSQ	25W	Yes	DC Bayonet
	WFL3	100W	No	DC Bayonet
	TWA, TWAC	100W	No	DC Bayonet
	TWH	150W	No	DC Bayonet
	TWP	250W	No	DC Bayonet
Floodlighting	ASF2	250W	No	DC Bayonet
	KFL3	100W	No	DC Bayonet
	TFA	250W	No	DC Bayonet
	TFR	250W	No	DC Bayonet
	TFL	250W	No	DC Bayonet
Rough Service Lighting	VGR1C, VGR2C	25W	Yes	DC Bayonet
	VG01C, VG02C	25W	Yes	DC Bayonet
	VG03C	25W	Yes	DC Bayonet

Refer to the Outdoor Emergency Application Guide at <http://ablweb> for further details.